

INSTRUCTION MANUAL

C5600 / C5605 / C5630 / C5635

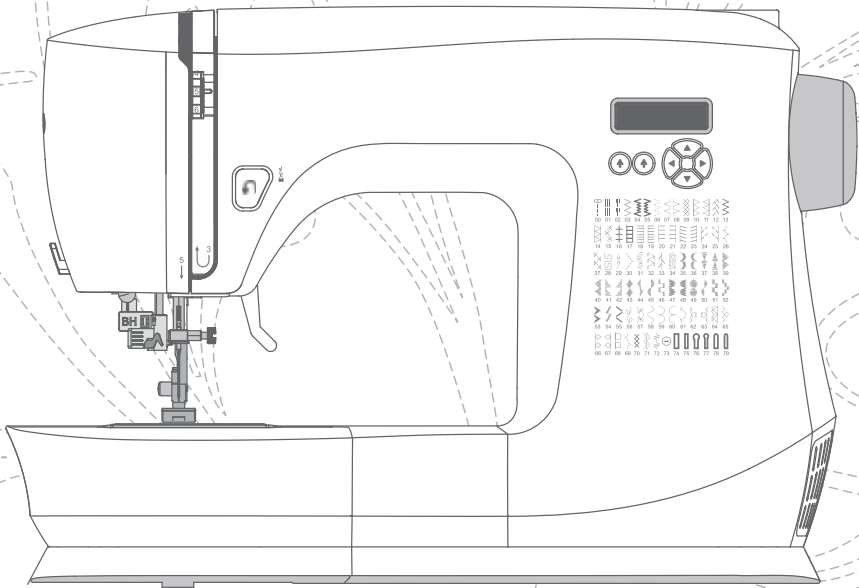

SINGER®

IMPORTANT SAFETY INSTRUCTIONS

Read all instructions before using this household sewing machine.

When using an electrical appliance, basic safety precautions should always be followed, including the following:

Keep the instructions at a suitable place close to the machine. Make sure to hand them over if the machine is given to a third party.

This appliance is intended for use by adults. The appliance can be used with adult supervision by (i) children aged from 8 to 12 years and (ii) persons with reduced physical, sensory or mental capabilities or lack of experience and knowledge if they have been given instruction concerning use of the appliance in a safe way and understand the hazards involved. Cleaning and user maintenance shall not be made by children without supervision. It is not allowed for anyone to play with the machine. Children up to 8 years are not allowed to use the machine.

WARNING – TO REDUCE THE RISK OF BURNS, FIRE, ELECTRIC SHOCK, OR INJURY TO PERSON:

- A sewing machine should never be left unattended when plugged in. The electrical socket, to which the machine is plugged in should be easily accessible. Always unplug this sewing machine from the electric outlet immediately after using and before cleaning, removing covers, lubricating or when making any other user servicing adjustments mentioned in the instruction manual.
- Do not allow to be used as a toy. Close attention is necessary when this sewing machine is used by or near children.
- Use this sewing machine only for its intended use as described in this manual. Use only attachments recommended by the manufacturer as contained in this manual.
- Never operate this sewing machine if it has a damaged cord or plug, if it is not working properly, if it has been dropped or damaged, or dropped into water. Return the sewing machine to the nearest authorized dealer or service center for examination, repair, electrical or mechanical adjustment.
- Never operate the sewing machine with any air openings blocked. Keep ventilation openings of the sewing machine and foot control free from the accumulation of lint, dust, and loose cloth.
- Keep fingers away from all moving parts. Special care is required around the sewing machine needle.
- Always use the proper needle plate. The wrong plate can cause the needle to break.
- Do not use bent needles.
- Do not pull or push fabric while stitching. It may deflect the needle causing it to break.
- Wear safety glasses.
- Switch the sewing machine off (“0”) when making any adjustment in the needle area, such as threading needle, changing needle, threading bobbin, or changing presser foot, etc.
- Never drop or insert any object into any opening.
- Do not use outdoors.
- Do not operate where aerosol (spray) products are being used or where oxygen is being administered.
- To disconnect, turn all controls to the off (“0”) position, then remove plug from outlet.
- Do not unplug by pulling on cord. To unplug, grasp the plug, not the cord.
- The foot control is used to operate the machine. Never place other objects on the foot control.
- Do not use the machine if it is wet.
- If the LED lamp is damaged or broken, it must be replaced by the manufacturer or its service agent or a similarly qualified person, in order to avoid a hazard.

- If the cord connected with the foot control is damaged, it must be replaced by the manufacturer or its service agent or a similarly qualified person, in order to avoid a hazard.
- The machine must only be used with foot control of type JF-1000 manufactured by Jaguar International Corporation or YC-485EC manufactured by Taiwan Yamamoto Electric Corp.

SAVE THESE INSTRUCTIONS

SERVICING OF DOUBLE INSULATED PRODUCTS

In a double-insulated product, two systems of insulation are provided instead of grounding. No ground means is provided on a double-insulated product, nor should a means for grounding be added to the product. Servicing of a double-insulated product requires extreme care and knowledge of the system and should be done only by qualified service personnel. Replacement parts for a double-insulated product must be identical to those parts in the product. A double-insulated product is marked with the words 'DOUBLE INSULATION' or 'DOUBLE INSULATED'.

TABLE OF CONTENTS

INTRODUCTION	1	Double Overlock Stitch	23
Intended Use	1	Ladder Stitch	23
Machine Overview	1	More Decorative Stitches & Ideas For Decorative Machine Stitching	24
Needle Area Overview	2	Darning and Mending	24
Top of Machine	2	Repair Large Holes	24
Overview Accessories	3	Repair Tears	24
Included Accessories	3	One-Step Buttonhole	25
Presser Feet	4	Sew Zippers	26
Optional Accessories	4	Centered Zipper	26
Stitch Overview	5	Hand-Look Quilt Stitch	27
Choosing Utility and Decorative Stitch Patterns	5	Button Sewing	27
PREPARATIONS	7	MAINTENANCE	28
Unpacking the Machine	7	Cleaning the Machine	28
Connect to the Power Supply	7	Cleaning the Feed Teeth and Shuttle Area	28
Packing Machine after Sewing	7	Cleaning the Sewing Machine and Foot Control	28
Free Arm/Removable Accessory Tray	8	Troubleshooting	29
Presser Foot Lifter	8	Technical Specification	32
Thread Knife	8		
Spool Pin	9		
Wind the Bobbin	10		
Removing Bobbin Case from Shuttle	10		
Inserting Bobbin Into Bobbin Case	11		
Inserting Bobbin Case Into Shuttle	11		
Picking Up Bobbin Thread	11		
Thread the Machine	12		
Needle Threader	13		
Needles	13		
Important Needle Information	14		
Selection Guide — Needle Size, Fabric, Thread	14		
Change the Needle	14		
Thread Tension	15		
Change the Presser Foot	15		
OPERATING YOUR MACHINE	16		
Machine Operation Controls	16		
Reverse Button	16		
Tie-Off	16		
Functions of Control Panel	16		
Stitch Number Selection Buttons	17		
Stitch Length and Stitch Width / Needle Position	17		
Helpful Messages	18		
SEWING	19		
Sewing	19		
Start to Sew – Straight Stitch	19		
Change Needle Position	19		
Change Sewing Direction	20		
Finish Sewing	20		
Straight Stretch Stitch	20		
Zigzag Stitching	21		
Multi-Step Zigzag Stitch	21		
Slant Overedge Stitch	21		
Overedge Stitch	22		
Feather Stitch	22		
Shell Stitch	23		

INTRODUCTION

Intended Use

Optimal use and maintenance are described in these instructions. This product is not intended for industrial or commercial use. Additional assistance, by region, may be found online at www.singer.com.

Machine Overview

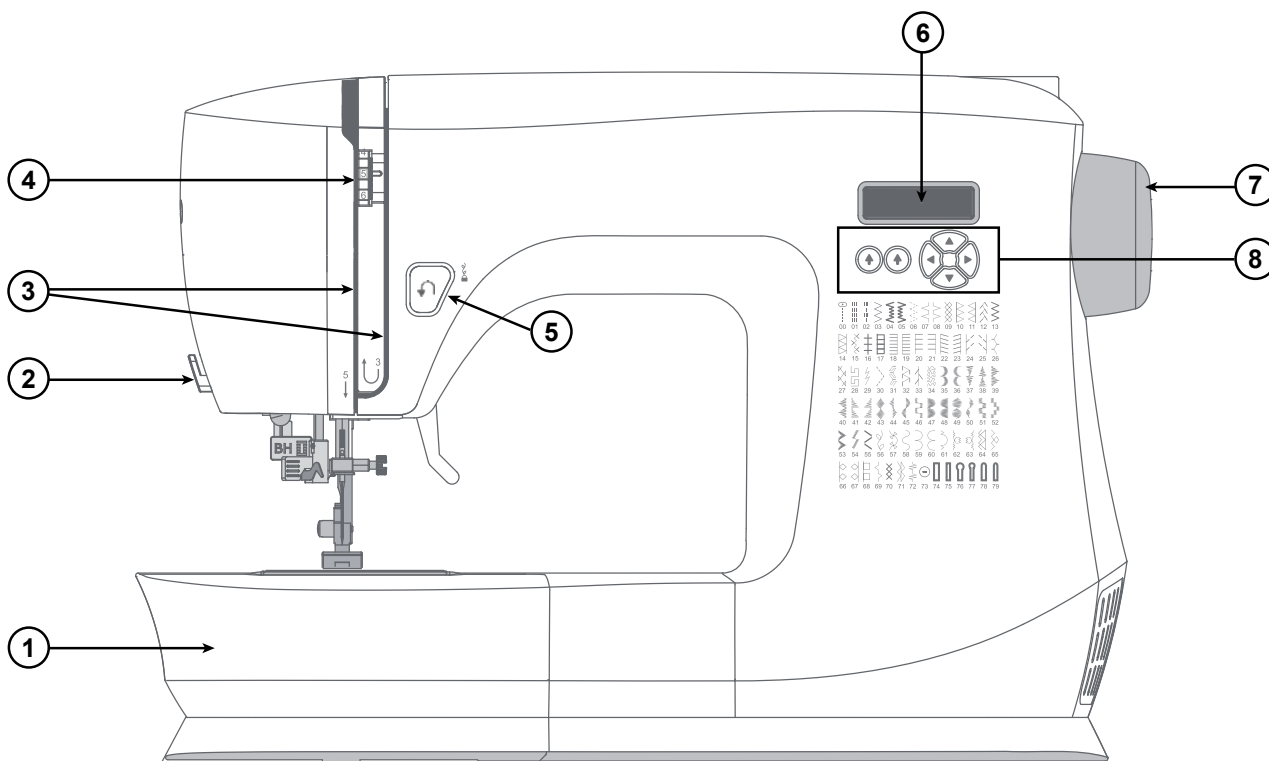

1. **Accessory Tray / Free Arm** — Provides a flat surface when sewing and allows storage for your accessories. Remove the accessory tray to use the free arm which makes it easier to sew, e.g., trouser hems and sleeves.
2. **Thread Knife** — For trimming thread ends at the end of sewing.
3. **Threading Slots** — Thread paths with tension discs and take up lever.
4. **Thread Tension Dial** — Adjustable for setting the desired tension for your stitch, thread and fabric.
5. **Reverse Button** — Press and hold to sew in reverse or to make a tie-off, e.g., when securing the beginning or ending of a seam.
6. **Display** — Current stitch and settings are displayed.
7. **Hand Wheel** — Used to manually control the movement of the needle and the thread take-up lever.
8. **Function Buttons** — Used for selecting stitches. Control the stitch width and the stitch length.

Needle Area Overview

1. **Needle Plate** — provides a flat area around presser foot for sewing. Guidelines indicate various seam allowances used to guide fabric while sewing.
2. **Feed Teeth** — feed the fabric under the presser foot when sewing.
3. **Presser Foot** — holds fabric against feed teeth which draw fabric under the presser foot as you sew.
4. **Presser Foot Holder Screw** — loosen the screw to remove the presser foot holder.
5. **Presser Foot Holder** — holds the presser foot.
6. **Presser Foot Release Button** — press this button to release the presser foot from the holder.
7. **Buttonhole Lever** — used for buttonhole sewing.
8. **Built-in Needle Threader** — thread the needle quickly and easily.
9. **Presser Foot Bar** — accommodates the presser foot holder.
10. **Needle Clamp Screw** — secures the needle.
11. **Needle Thread Guide** — helps maintain thread flow when sewing.

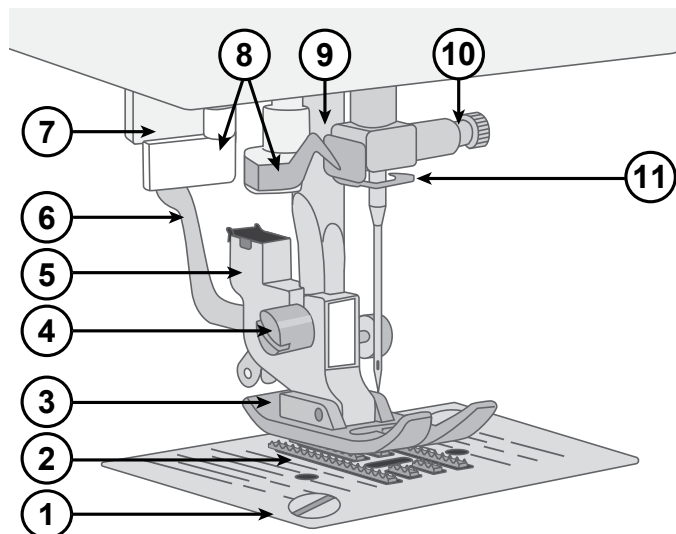

Top of Machine

1. Bobbin winding tension disc
2. Thread guides
3. Handle
4. Spool pin
5. Hole for auxiliary spool pin
6. Bobbin winding spindle
7. Bobbin winding stopper
8. Thread tension discs
9. Thread take-up lever

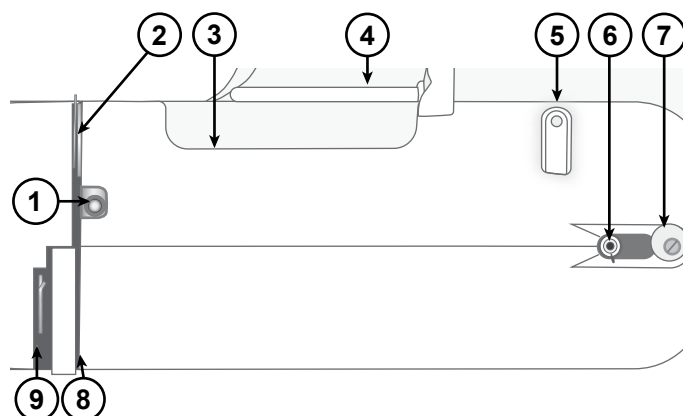

Overview Accessories



Bobbin x4 — Only use the type of metal bobbins delivered with your machine (SINGER® Class 15 metal bobbins). One of the bobbins is inserted in the machine upon delivery.

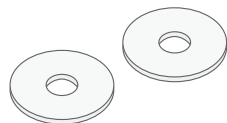

Felt Pad x2 — Used to cushion the spool of thread when using the Auxiliary Spool Pin.

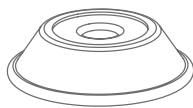

Spool Cap — For various thread spool styles.

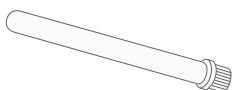

Auxiliary Spool Pin — For sewing with large thread spools or when using specialty threads.

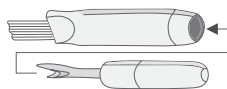

Brush and Seam Ripper — Used to remove stitches/brush off lint.



Screwdriver — Used to remove the needle plate, presser foot holder or needle screw.



Edge/Quilting Guide — Used for straight and accurate sewing, e.g., when quilting. Insert the guide into the slot at the back of the presser foot holder. Adjust the position to fit your project.



Darning Plate — Use the darning plate when you need to control fabric feeding for button sewing, free motion work and free motion darning. Raise needle and presser foot, and position darning plate onto the needle plate with the two pins on the back inserted to the holes of needle plate.

Included Accessories (Not Pictured)

- Needles
- Foot control
- Power cord

Presser Feet

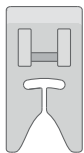

All Purpose Foot

(attached to the machine upon delivery)

This foot is used for general sewing on most types of fabric. The bottom of the foot is flat, so that the fabric is held down firmly against the feed teeth while sewing. It also has a wide slot so that the needle can move from left to right, depending on which stitch you sew.

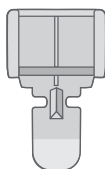

Zipper Foot

This foot is used for inserting zippers. Attach the foot to the presser foot holder on either side of the foot, depending on which side of the zipper is being sewn. The Zipper Foot can also be used to create and insert piping.

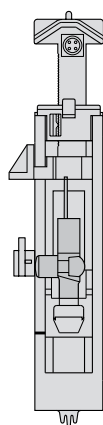

1-Step Buttonhole Foot

This foot allows you to make perfectly sized buttonholes for your button. It has a space at the back for a button, used to set the size of the buttonhole. The machine will automatically sew a buttonhole to fit that button size.

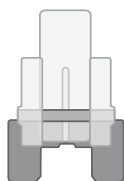

Button Sewing Foot

The Button Sewing Foot quickly and neatly sews on buttons, eliminating the need to sew them manually. The foot sits on top of the button, with the opening positioned around the holes.

























Optional Accessories









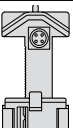

Additional optional accessories are available for your machine. Check with your authorized SINGER® retailer or singer.com for more information.

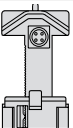
Stitch Overview

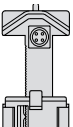
Choosing Utility and Decorative Stitch Patterns

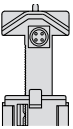
The stitches described in the below chart are utility stitches, used mainly for utility sewing. When sewing, use a thread tension between 3–5. Always test sew on a piece of scrap fabric, and adjust the tension if necessary.

			Application
	Straight Stitch Center Position		The basic stitch used for sewing. The most common use for a straight stitch is to sew two pieces of fabric together.
	Straight Stretch Stitch		Stronger than a regular straight stitch, on stretch knit fabrics, because it locks three times — forward, backward and forward again. Use it to reinforce seams of sportswear and for curved seams which take a lot of strain.
	Stretch Stitch		For seams in tricot and stretch fabrics.
	Zigzag Stitch		A very versatile stitch for decorative sewing, appliqué, attaching trims, and more.
	Multi-Step Zigzag Stitch		Finish seam allowances to prevent the fabric from unravelling. When seam finishing, the smaller step of the stitches will help keep fabric more flat than a regular zigzag. It can also be used for mending tears and sewing elastic.
	Overlock Stitch		Sew seam and overcast in one step. For medium and medium/heavy stretch fabrics.
	Slant Overedge Stitch		Seam and overcast in one step. For medium and heavy stretch fabrics.
	Closed Over- lock Stitch		Sew decorative hems and overlapped seams, belts and bands. For medium/heavy stretch fabrics.
	Honeycomb Stitch		For elastic insertion, decorative stitching, smocking, couching and hemming.
	Ric-Rac Stitch		The pleasing appearance of this stitch enables it to be used for decorative topstitching or for attaching laces and trims. It is also ideal for quilting applications and edge-joining.
	Satin Stitch		This is a closely spaced zigzag stitch for appliqué, bar-tacking, etc. Slightly loosen the top thread tension and manually adjust the stitch length between 0.5 and 2.0 for satin stitching. Use a backing of stabilizer or interfacing to avoid puckering.

			Application
	Buttonhole		Sew buttonholes on home decór, garments, crafts and more.
	Rounded Bartack Buttonhole		For light weight fabrics.
	Rounded Bartack Buttonhole, Reinforced		For light weight fabrics.
	Keyhole Buttonhole		Square end for tailored jackets, coats, etc.
	Keyhole Buttonhole, Reinforced		Square end for tailored jackets, coats, etc.
	Button Sewing Stitch		For sewing on buttons.

PREPARATIONS

Unpacking the Machine

1. Place the box on a steady, flat surface. Lift the machine out of the box, and remove the packaging.
2. Remove all outer packing material and the plastic bag.
3. Wipe off the machine with a dry cloth to remove any lint and/or excess oil around the needle area.

Note: Your sewing machine is adjusted to provide the best stitch result at normal room temperature. Extreme hot and cold temperatures can affect the sewn result.

Connect to the Power Supply

Among the accessories you will find the power cord and the foot control.

Note: Consult a qualified electrician if in doubt as how to connect the machine to the power source. Unplug the power cord when the machine is not in use.

On the bottom right side of the sewing machine, you find the connecting sockets and the ON/OFF button.

1. Connect the foot control cord to the front socket on the bottom right side of the machine (A).
2. Connect the power cord to the rear socket on the bottom right side of the machine (B). Plug the cord into the wall socket.
3. Press the ON/OFF switch (C) to "I" to turn on power and light.

Note: After turning off the machine, residual power may remain in the machine. This could cause the light to stay on for a few seconds while the power is consumed. This is normal for an energy efficient appliance.

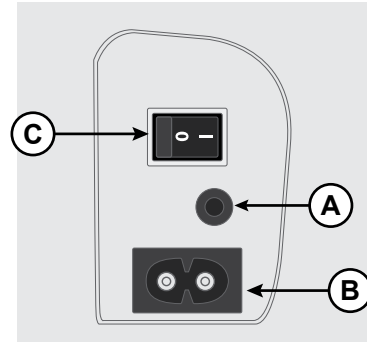

For the USA and Canada

This sewing machine has a polarized plug (one blade wider than the other). To reduce the risk of electric shock, this plug is intended to fit in a polarized outlet only one way. If the plug does not fit fully in the outlet, reverse the plug. If it still does not fit, contact a qualified electrician to install the proper outlet. Do not modify the plug in any way.

Packing Machine after Sewing

1. Switch the main switch off. After switching off, residual power may still remain in the machine. This may cause the light to stay on for a few seconds while the power is consumed. This is normal behavior for an energy efficient appliance.
2. Unplug the cord from the wall socket and then from the machine.
3. Wind the cord around the foot control for easy storage.
4. Place all accessories in the accessory tray. Slide the tray on to the machine around the free arm.
5. Place the foot control and cord in the space above the free arm.
6. Place the soft cover on the machine to help protect it from dust and lint.

Free Arm/Removable Accessory Tray

Store presser feet, bobbins, needles and other accessories in the accessory tray so that they are easily accessible.

Keep the accessory tray on the machine to provide a larger, flat work surface.

Use the free arm to facilitate sewing trouser legs and sleeve hems. To use the free arm, slide off the accessory tray. When attached, a hook keeps the accessory tray securely attached to the machine. Remove the tray by sliding it to the left.

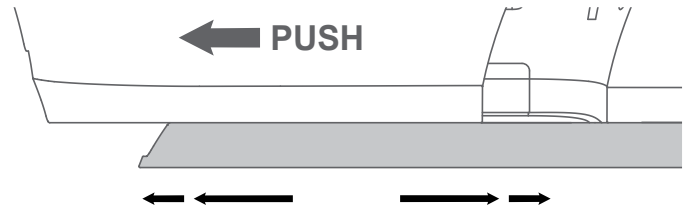

Presser Foot Lifter

The presser foot lifter is located at the right side of the sewing machine head. The lever is used to raise and lower the presser foot. Raise the lever up for machine threading, lower it for sewing.

By raising the presser foot lifter and then pressing it farther upwards, the lift height of the presser foot is increased to an extra height allowing you to place thick fabric layers under the foot.

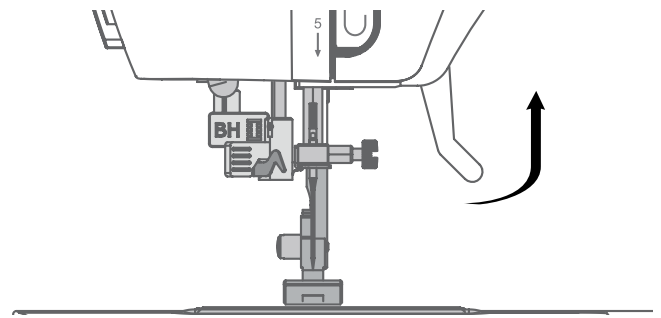

Thread Knife

To use the thread knife, pull the thread from back to front as illustrated. Doing this will leave the thread ends long enough so that the needle doesn't become unthreaded when you start to sew again.

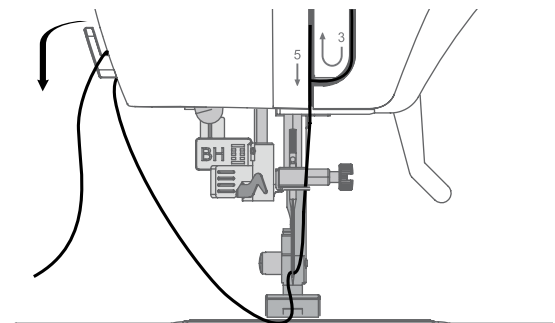

Spool Pin

Your machine has two spool pins, a main spool pin and an Auxiliary Spool Pin. The spool pins are designed for various types of thread. The main spool pin is used in a horizontal position (the thread reels off the spool) and the Auxiliary Spool Pin in a vertical position (the thread spool rotates). Use the horizontal position for normal threads and the vertical position for large spools or specialty threads.

Main Spool Pin

Place the thread spool on the spool pin. Make sure that the thread reels off the spool counter clockwise and slide on a spool cap (A). The flat side of the spool cap should be pressed firmly against the spool. There should be no space between the spool cap and the thread spool.

Note: Not all thread spools are manufactured in the same way. If you experience problems with the thread, turn it in the opposite way or use the vertical position.

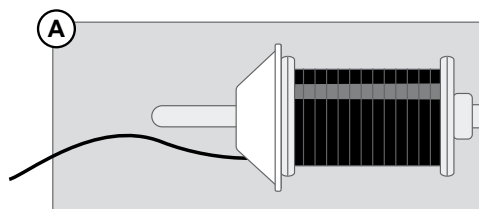

Auxiliary Spool Pin

The Auxiliary Spool Pin is used when winding a bobbin thread from a second spool of thread or when sewing with large spools or with specialty threads. Insert the Auxiliary Spool Pin into the designated hole at the top of the machine. Place a felt pad under the thread spool. This is to prevent the thread from reeling off too fast. Do not place a spool cap on top of the spool pin as that would prevent the spool from rotating.

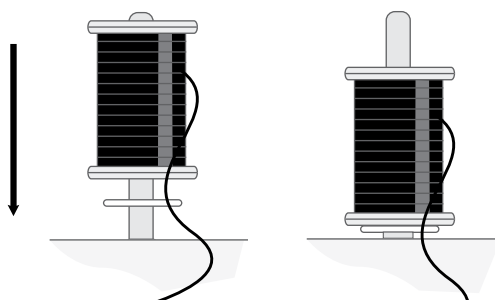

Wind the Bobbin

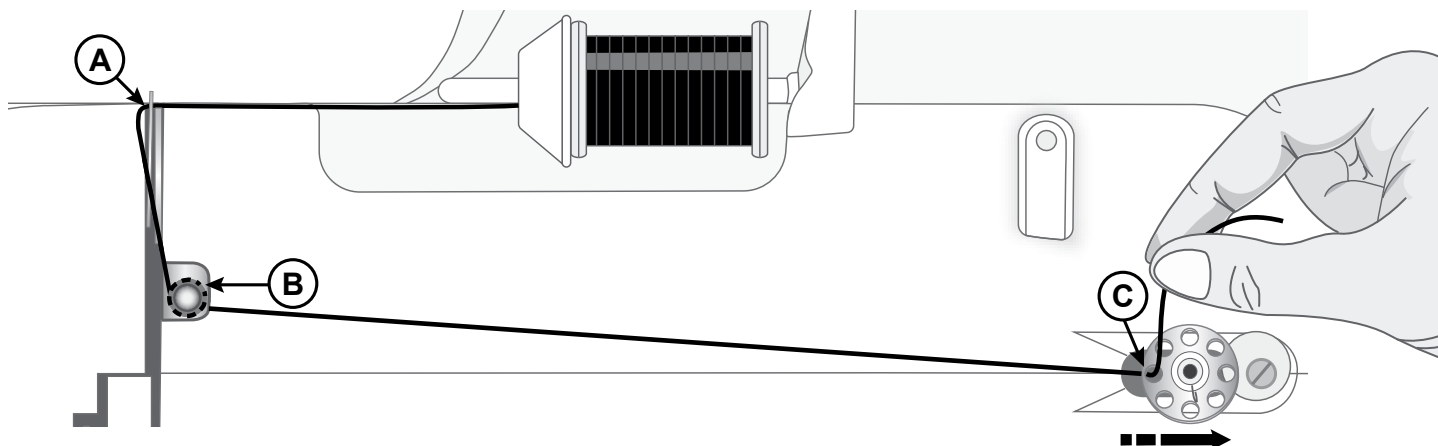

1. Place the thread spool on the spool pin. Slide a spool cap firmly against the spool.
2. Place the thread around the thread guide (A) from back to front and around the bobbin winding tension disc (B), making sure that the thread is pulled snugly between the discs.
3. Thread through the hole in the bobbin (C) from the inside to the outside.
4. Place the bobbin on the bobbin winding spindle. Make sure the bobbin is pushed down firmly.
5. Push the bobbin winding spindle to the right. Hold the thread end, and press the foot control to start winding.

After a few turns, take your foot off the foot control to stop winding. Cut the excess thread tail above the bobbin, making sure to trim it close to the bobbin. Step on the foot control to resume winding. When the bobbin is full, the bobbin winding will slow down and stop automatically.

Note: You can also start the winding by long pressing the start/stop button.

6. Push the bobbin winding spindle to the left. Remove the bobbin and cut the thread.

Note: When the bobbin winding spindle is pushed to the right, the machine will not sew. Make sure to push the bobbin spindle back to the sewing position (left) before sewing.

Removing Bobbin Case from Shuttle

1. Raise the needle to its highest position by rotating the hand wheel toward you (counter-clockwise).
2. Remove the extension table / accessory box. Open the bobbin access cover by pulling it down. With your fingers, pull open the bobbin case latch as shown, and take out the bobbin case from the shuttle.
3. Release the latch, and bobbin will drop out of the case.

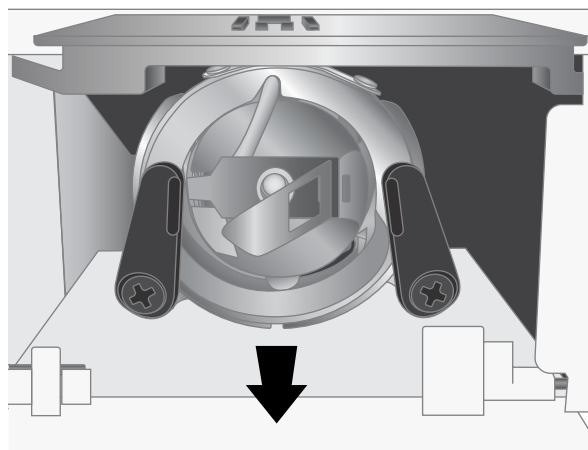

Inserting Bobbin Into Bobbin Case

1. Hold the bobbin in your right hand with the thread running clockwise, while holding the case in your left hand.
2. Insert the bobbin into the case with about 4" (10 cm) of thread showing outside of the case.
3. While holding the bobbin securely down in the case, pull the thread through the slit in the case and then underneath the flat tension spring. It will click when the thread is seated correctly in the tension.
4. Keep about 4" (10 cm) tail of thread trailing outside of the case.

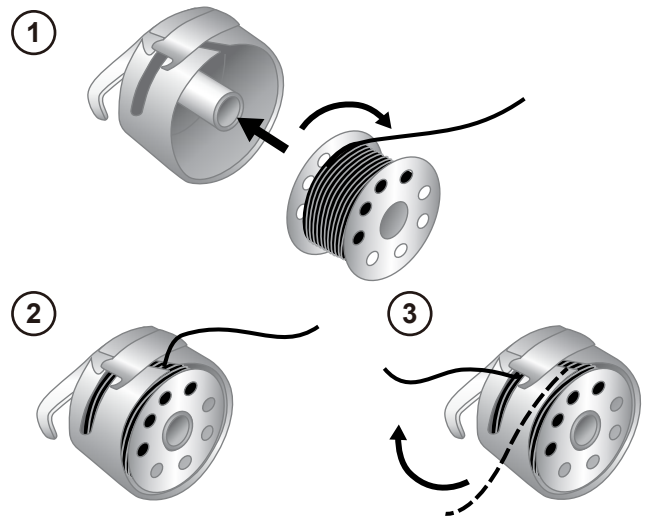

Inserting Bobbin Case Into Shuttle

1. Hold the latch open, with locating pin straight up.
2. Slide the bobbin case onto the center spindle of the shuttle, keeping the thread toward you.
3. Release the latch to lock the bobbin case in place.

NOTE: Be sure the locating pin fits into the locating groove at the top of the shuttle.

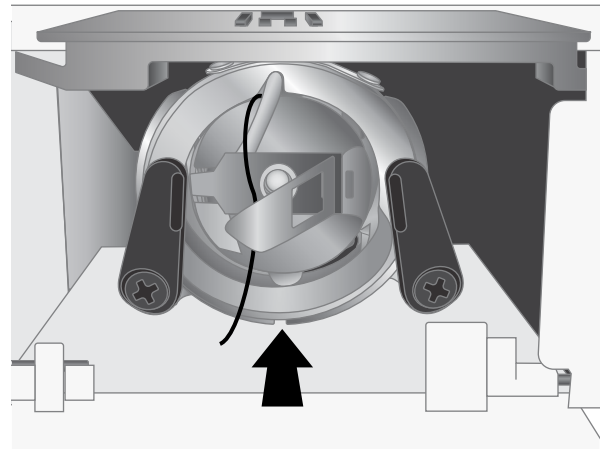

Picking Up Bobbin Thread

1. Raise the presser foot lifter.
2. Holding needle thread loosely with your left hand, turn hand wheel toward you (counter-clockwise) with your right hand, first lowering the needle and continuing until the needle comes to its highest position.
3. Lightly pull up the top thread, and pick up bobbin thread, which will appear through the needle plate slot.
4. Pull both top and bobbin threads together toward the back of the machine under the presser foot, leaving about 6" (15 cm) clear.

NOTE: A quick way to pick up the bobbin thread is, with straight stitch selected, touch and release the reverse button. Your machine will perform one down-up cycle and stop with the needle up. Always stopping with the needle "fully up" is one of the features of your computerized sewing machine.

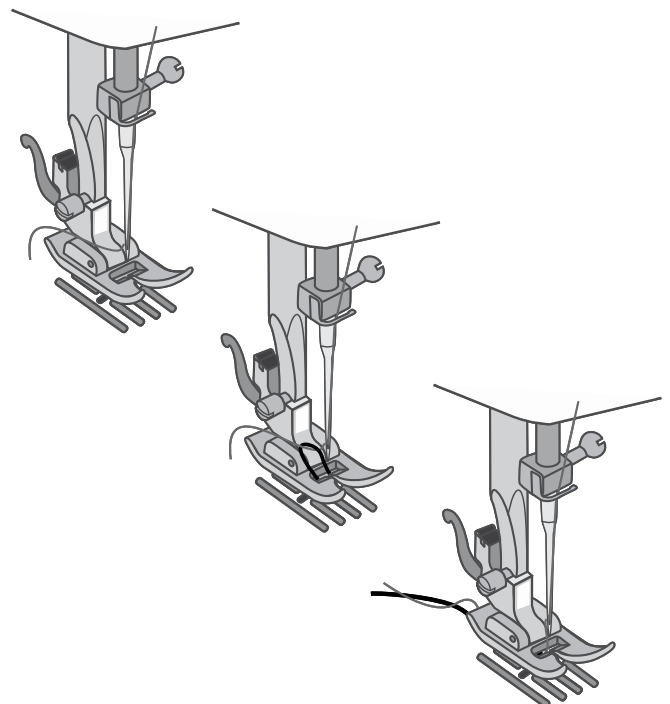

Thread the Machine

Important! Make sure that the presser foot is raised and the needle is in its highest position by turning the handwheel toward you. This is very important to help ensure that the machine is correctly threaded. Not doing so can result in poor stitch quality when you start to sew.

1. Place the thread on the spool pin and fit the appropriately sized spool cap.
2. Pull the thread around the thread guide (A) from back to front.
3. Continue bringing the thread down through the right threading slot (B), around the U-turn, then back upwards through the left threading slot.
4. Bring the thread from the right into the take-up lever (C) and down in the left-hand threading slot and to the needle thread guide (D).
5. Thread the needle from front to back.

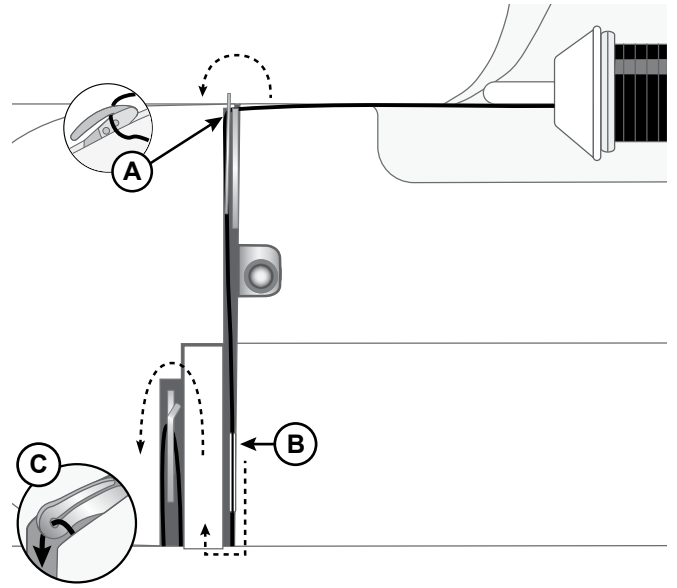

Machine from above

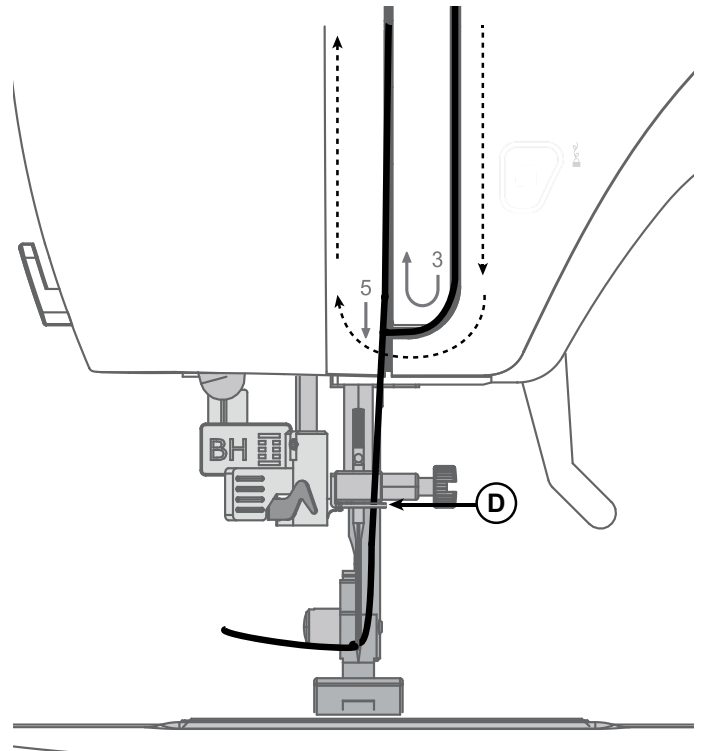

Machine from front

Needle Threader

The built-in needle threader allows you to thread the needle quickly and easily.

The needle must be in its highest position to use the built-in needle threader. Turn the hand wheel towards you until the needle is in its highest position. It is also recommended that you lower the presser foot.

- Use the handle (A) to pull the needle threader all the way down and push toward the back. The metal flanges cover the needle. A small hook will pass through the needle eye (B).
- Place the thread from the back over the thread guide (C) and under the small hook (D).
- Let the needle threader gently swing back. The hook pulls the thread through the needle eye and forms a loop behind the needle. Pull the thread loop out behind the needle.
- Raise the presser foot and place the thread under it.
- Pull out about 6–8" (15–20cm) of thread beyond the needle eye. This will prevent the machine from coming unthreaded when you start to sew.

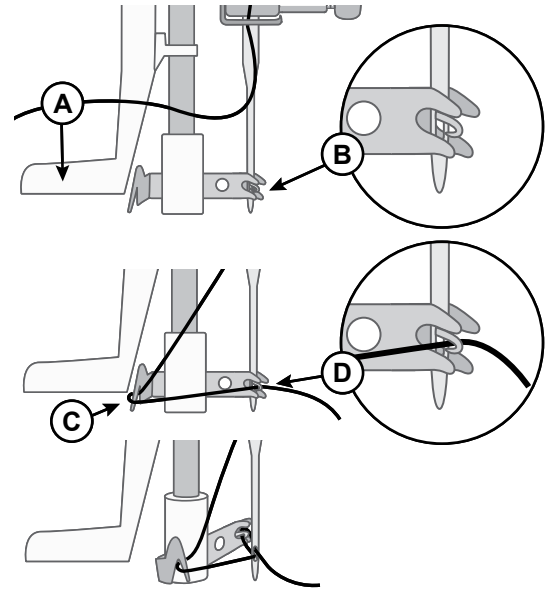

Note: The needle threader is designed to be used for size 70-110 needles. You cannot use the needle threader for size 60 needles or smaller; wing needles or twin needles. There are also some optional accessories that require manual threading of the needle. When threading the needle manually, make sure that the needle is threaded from front to back.

Needles

The sewing machine needle plays an important role in successful sewing. Use only quality needles. We recommend needles of system 130/705H. The needle package included with your machine contains needles of the most frequently used sizes.

 *Be sure to match the needle to the thread you are using. Heavier threads require a needle with a larger needle eye. If the needle eye is too small for the thread the needle threader may not work properly.*

Universal Needle



Universal needles have a slightly rounded point and come in a variety of sizes. For general sewing in a variety of fabric types and weights.

Stretch Needle



Stretch needles have a ball point and a special scarf to eliminate skipped stitches when there is a flex in the fabric. For knits, swimwear, fleece, synthetic suedes and synthetic leathers.

Denim Needle



Denim needles have a sharp point to penetrate tightly woven fabrics without deflecting the needle. For canvas, denim, microfibers.

Embroidery Needle



Embroidery needles have a special scarf, a slightly rounded point and a slightly larger eye to avoid damage to thread and materials. Use with metallic and other specialty threads for free-motion embroidery and decorative sewing.

Wing Needle

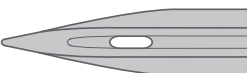

Wing needles have wide extensions on each side of the needle to poke holes in the fabric when sewing entredeux and other hemstitches on natural fiber fabrics.

 *To help prevent needle breakage, use only medium/low sewing speed and the recommended needle for sewing thick fabrics.*

Important Needle Information



Change the needle often. As a general rule, needles should be changed every 6-8 hours of actual stitching time.

Always use a straight needle with a sharp point and make sure the point is not bent or damaged (A).

A damaged needle (B) can cause skipped stitches, breakage or snapping of the thread. It can also damage the needle plate.

Do not use asymmetrical twin needles (C), they can damage your sewing machine.

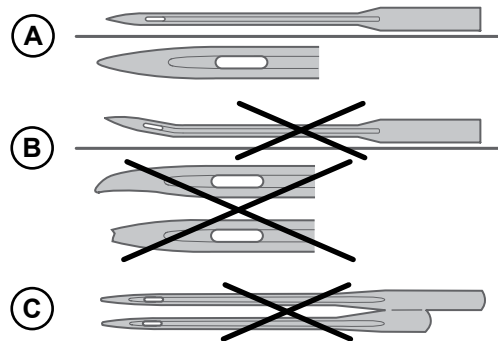

Selection Guide — Needle Size, Fabric, Thread

Needle Size	Fabric	Thread
70 (9) 80 (12)	Lightweight fabrics: Fine cotton, voile, silk, muslin, interlock, tricot, jersey, crepe, polyester, chiffon, organza, organdy	Light duty all purpose thread
80 (12) 90 (14)	Medium weight fabrics: Quilting cotton, satin, double knit, lightweight wool, rayon, polyester, lightweight linen	Use polyester threads on synthetic fabrics and all-purpose or cotton thread on natural fabrics for best results.
90 (14)	Medium weight fabrics: Firm woven, medium weight linen, cotton/polyester blend, terrycloth, chambray, double knit	
100 (16)	Heavy weight fabrics: Canvas, wool, denim, home decor, fleece, heavy knit	Polyester or all-purpose thread
110 (18)	Heavy weight fabrics: Coat weight wool, upholstery fabrics	Heavy duty thread for needle, with all-purpose thread for the bobbin.

Change the Needle

Note: Before you begin changing the needle, it can be helpful to place a small piece of paper or fabric underneath the needle area, over the hole in the needle plate, so that the needle doesn't accidentally fall down into the machine.

1. Loosen the needle clamp screw. If it feels tight, use the screwdriver from your accessories to aid with loosening the screw.
2. Remove the needle.
3. Push the new needle upwards into the needle clamp with the flat side of the needle away from you.
4. When the needle will go up no further, tighten the screw securely.

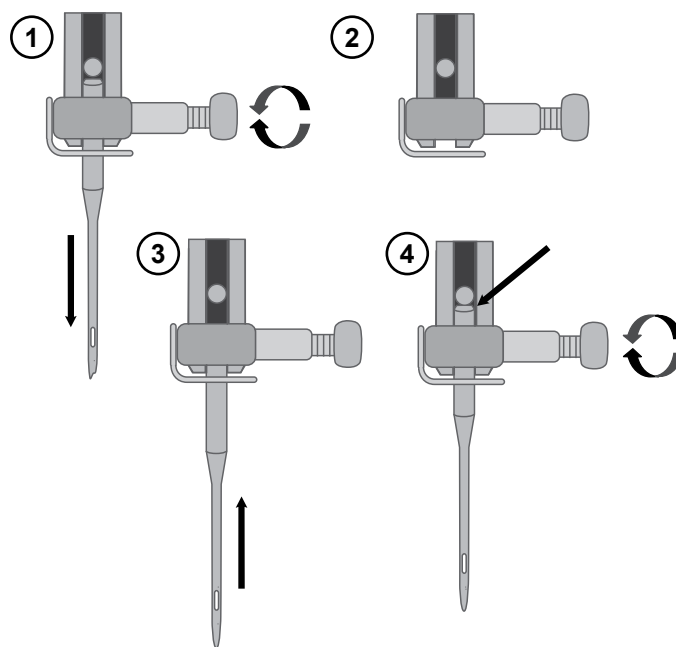

Thread Tension

To set the thread tension, turn the dial on the machine. Depending on the fabric, thread, etc, the tension may need to be adjusted. For the best stitch appearance and durability, make sure the needle thread tension is correctly adjusted. For general sewing, the threads evenly meet between the two layers of fabric (A).

If the bobbin thread is visible on the top side of the fabric, the needle thread tension is too tight (B). Reduce the needle thread tension.

If top thread is visible on the underside of the fabric, the needle thread tension is too loose (C). Increase the needle thread tension.

For decorative stitches and buttonholes, the top thread should be visible on the underside of the fabric.

Make a few tests on a scrap piece of the fabric you are going to sew and check the tension.

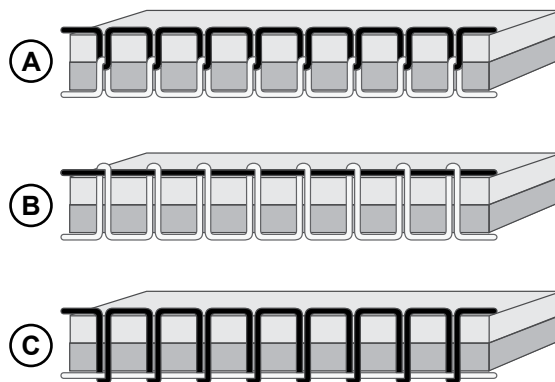

Change the Presser Foot

1. Push presser foot release lever to remove the foot.
2. Place the desired foot on the needle plate aligning the presser foot pin with the foot holder.
3. Lower the presser foot lifter so that the foot holder snaps on the foot.

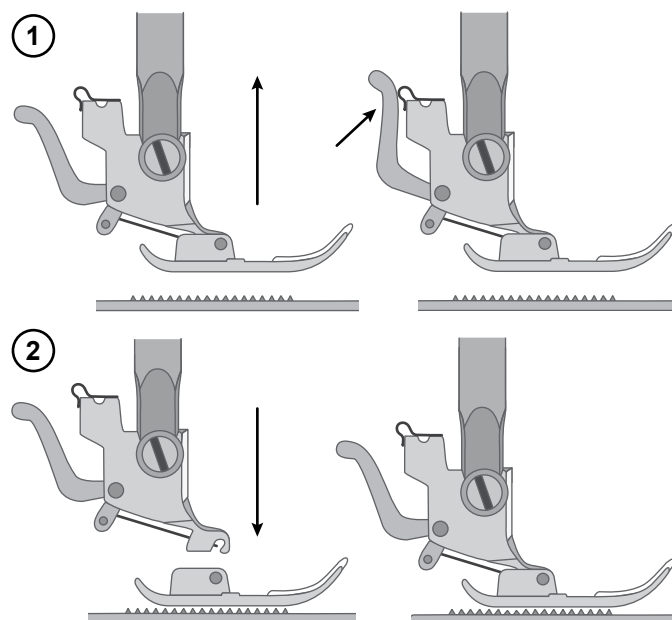

OPERATING YOUR MACHINE

Machine Operation Controls

Reverse Button



The Reverse Button has two different functions, depending on what stitch has been selected.

Utility Stitches (*stitch no. 00,03*)

Press and hold the Reverse button to sew in reverse. Release it to resume sewing forward. The machine sews in reverse only as long as the reverse button is pressed.

Tie-Off



When pressed the machine immediately sews three tie-off stitches and stops automatically.

Utility Stitches (*stitch no. 01, 02 and 04-73*)

Press the Reverse button and the machine sews 3 tie-off stitches then stops automatically.

Functions of Control Panel

The Functions Control Panel are used to select and adjust stitches. Each functionality is listed and described further below.

1. Display
2. Stitch number
3. Stitch width/needle position of straight stitch
4. Stitch length
5. Stitch selection buttons
6. Manual adjustment buttons for stitch width/ needle position
7. Manual adjustment buttons for stitch length

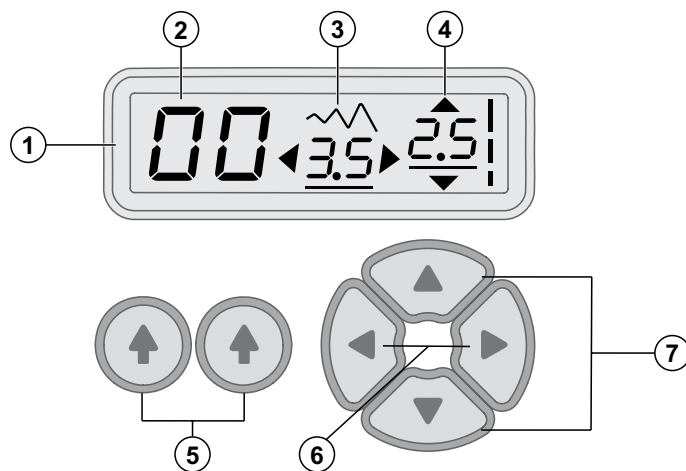

Stitch Number Selection Buttons

When the machine is turned on, straight stitch is selected and pop-up screen for individual preference settings appears on the display. To select stitch patterns, use left button for stitch number selection to select left digit and right button to select the right digit referring to stitch number reference guide. The corresponding stitch numbers are shown on the Stitch Charts available at the lower right of the machine, under the Control Panel.

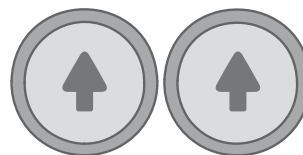

Stitch Length and Stitch Width / Needle Position

Your sewing machine will produce your stitching requirements at an Default stitch Length and Width. Default settings of stitch length and width are underlined on the display. You can manually change the length, width or needle position for straight stitch according to your preference by pressing the manual adjustment buttons.

The position of the needle when sewing straight stitch may be adjusted to any of the 13 different positions with the Stitch Width Control. Press the left control button to position the needle to the left, and press the right button to move the needle to the right.

NOTE: Some patterns offer more options for manual adjustments than others.

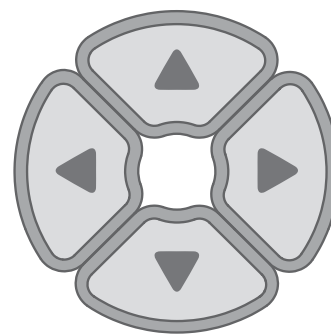

Helpful Messages

If an incorrect operation is made, a helpful message will be displayed. When a helpful message is displayed, fix the problem following the instructions below.

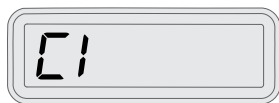

Bobbin winder is moved to right (operating position) during sewing.
— Check bobbin winder and move it to left.

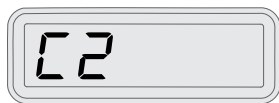

Buttonhole lever is not lowered or raised.
— Lower buttonhole lever when sewing buttonholes.
— Raise buttonhole lever when sewing stitch patterns.

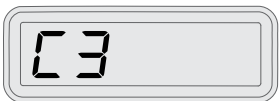

Foot control plug is pulled out, while operating foot control.
— Push in foot control plug.

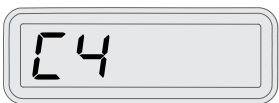

Machine is locked up due to thread entangled with bobbin case or rotation interrupted forcibly.
— Turn off power switch and eliminate the problem that caused the machine to stop.

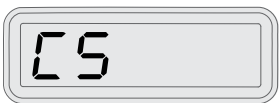

Reverse/tacking stitch button is pushed, while buttonhole stitch is selected.
— Tacking stitch is made automatically after buttonhole stitch is completed. It is not necessary to push the reverse/tacking stitch button.

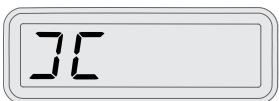

Bobbin winder is in operation. Bobbin winder is in operation.
— Move bobbin winder to left when it is not used.

SEWING

Sewing

Next to each stitch or sewing technique described in this section of the manual is a chart showing the recommended settings and presser foot. See sample of the chart to the right.

The recommended settings are also shown on the display, but might need adjustment to fit a special technique.

Note: Some fabrics have a lot of excess dye which can cause discoloration on other fabric but also on your sewing machine. This discoloring may be very difficult or impossible to remove. Fleece and denim fabric in especially red and blue often contain a lot of excess dye. If you suspect that your fabric/ready-to-wear garment contains a lot of excess dye, always pre-wash it before sewing to avoid the discoloring.

Note: For best sewing result, use the same thread on top and bobbin. If sewing with specialty/decorative threads, use regular sewing thread in the bobbin.

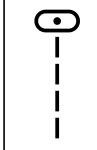
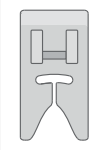
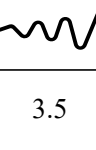
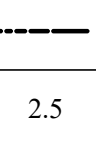
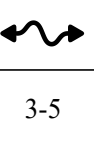
				
(A)	(B)	3.5	2.5	3-5

A. Stitch

B. Presser foot

C. Stitch width in mm

D. Stitch length in mm

E. Thread tension

Start to Sew – Straight Stitch



Set your machine for straight stitch (see chart to the right).

Raise the presser foot and position the fabric under it, next to a seam allowance guide line on the needle plate.

Place the top thread underneath the presser foot. Pull both threads under the presser foot toward the back of the machine, leaving about 6" (15cm) clear.

Lower the needle to the point where you want to start. Bring the threads toward the back and lower the presser foot. Press the foot control. Gently guide the fabric along the seam guide letting the machine feed the fabric (A).

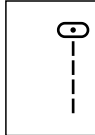
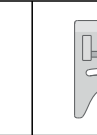
To secure the beginning of a seam, press and hold the reverse button. Sew a few reverse stitches. Release the reverse button and the machine will sew forward again (B).

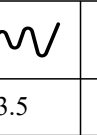
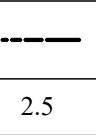
				
		3.5	2.5	3-5

Set up for straight stitch

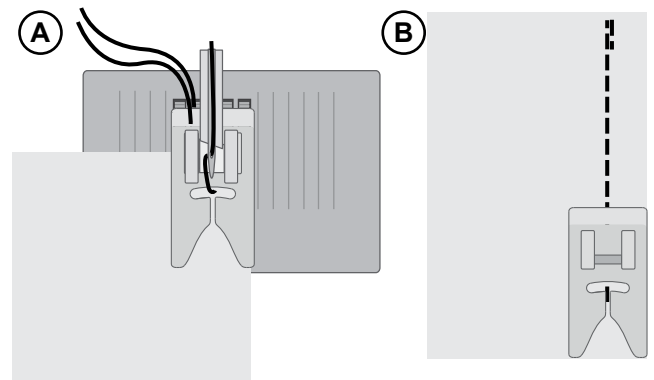

Change Needle Position

Some sewing is done more easily by changing the needle position, e.g., topstitching a collar or sewing in a zipper. The needle position is adjusted with the stitch width control buttons.

Change Sewing Direction

To change sewing direction, stop the machine with the needle down. Raise the presser foot.

Pivot the fabric around the needle to change sewing direction as desired. Lower the presser foot and continue sewing in the new direction.

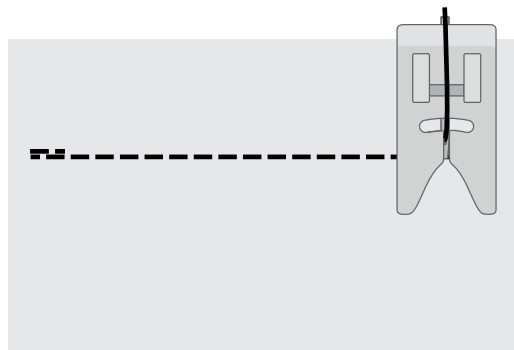

Finish Sewing

Press and hold the Reverse button and sew a few stitches in reverse when you reach the end of the seam. Release the button and sew forward again to the end of the seam. This will secure the seam so the stitches don't unravel.



Turn the handwheel toward you to raise the needle to its highest position. Raise the presser foot and remove the fabric, pulling the threads to the back.

Pull the threads up and into the thread knife so that the threads are cut the proper length and your needle won't come unthreaded when you start the next seam.

Straight Stretch Stitch

This stitch is stronger than regular straight stitch, due to the fact that it is a triple and elastic stitch. The Straight Stretch Stitch can be used for heavy stretch fabrics, for crotch seams which are subject to considerable strain and for topstitching heavy fabrics.

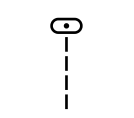
Carefully guide the fabric while sewing as the fabric moves back and forth.

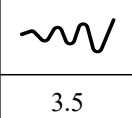
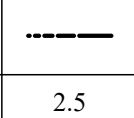
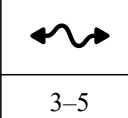
				
		3.5	2.5	3-5

Set up for Straight Stretch Stitch

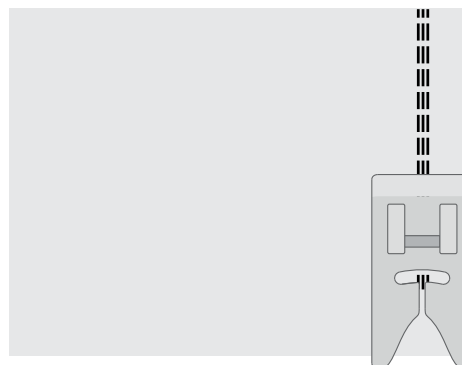





Zigzag Stitching

The top thread may appear on the bottom depending on the thread, fabric, type of stitch and sewing speed, but the bobbin thread should not appear on the top of the fabric. If bobbin thread is pulling to the top or you are experiencing puckering, slightly reduce the tension with the Thread Tension Control.

Multi-Step Zigzag Stitch

Multi-step zigzag stitch is used to overcast raw edges. Make sure the needle pierces the fabric on the left side and overcasts the edge on the right side.

The stitch can also be used as an elastic stitch to allow seams to stretch when sewing knit fabrics.

				
		3.0–5.0	1.0	3–5

Set up for multi-step zigzag stitch







Slant Overedge Stitch

The slant overedge stitch sews the seam and overcasts the edge all at one time, perfect for stretch fabrics. This stitch is more elastic than normal seams, very durable and quickly sewn.

Place the fabric under the presser foot aligning the edge of the presser foot with the edge of the fabric. Once the seam is finished, trim excess fabric outside the seam.

Tip: You can also use an Overcasting Foot, if desired.

				
		5.0	2.5	3–5



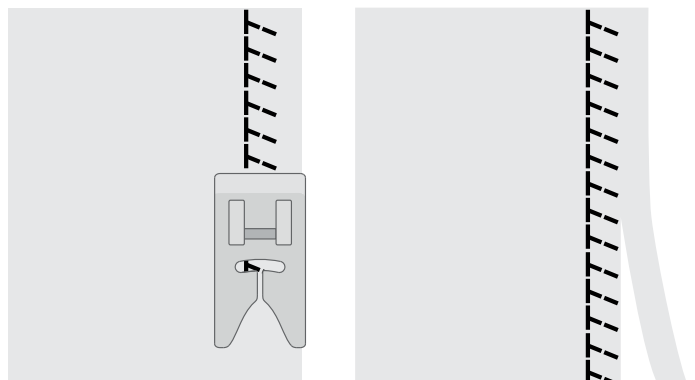

Set up for slant overedge stitch



Overedge Stitch

This is the same type stitch used by the garment industry in making sportswear - it forms and finishes the seam in one operation. It's very effective for use in repairing raw or worn seams of garments.

Tip: You can also use an Overcasting Foot, if desired.



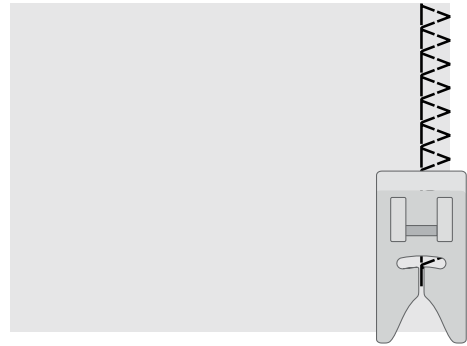

				
		5.0	2.5	3-5

Set up for overedge stitch



Feather Stitch

The pleasing appearance of this stitch enables it to be used for decorative topstitching or for attaching laces and trims. It is also ideal for quilting applications and edge-joining.



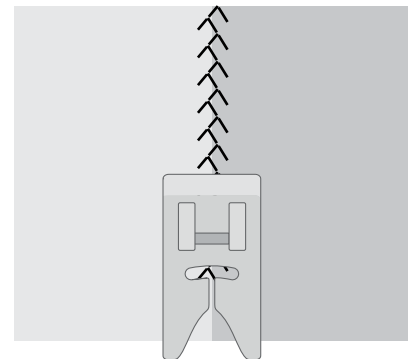

				
		5.0	2.5	3-5

Set up for feather stitch



Shell Stitch

Turn under the raw edge and press. Place the fabric right side up so that the zigzag part of the stitch sews just over the folded edge, pulling the fabric in to form a shell hem. Trim away excess fabric from the backside, close to the stitching line.



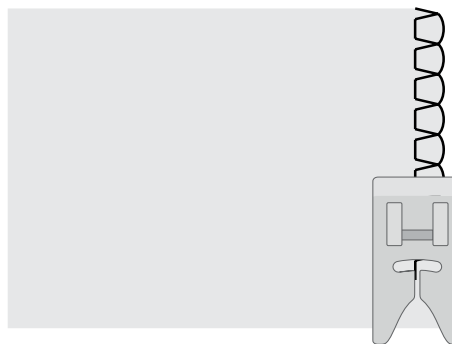

				
		5.0	2.5	3-5

Set up for shell stitch



Double Overlock Stitch

The Double overlock stitch has three main uses. It is perfect for attaching flat elastic, for overcasting, and for seaming and overcasting in one operation. It is primarily used on slightly stretch fabrics and non-stretch fabrics such as linen, tweed, and medium to heavy-weight cotton.



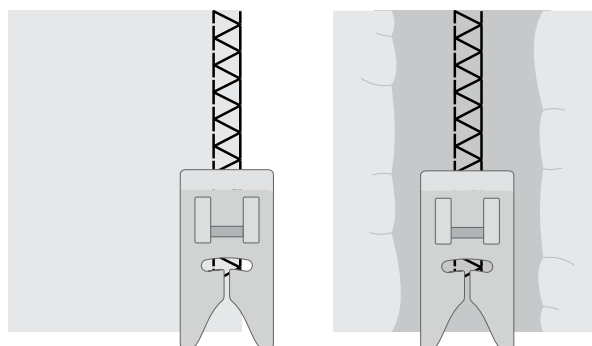

				
		5.0	2.5	3-5

Set up for double overlock stitch



Ladder Stitch

The Ladder stitch is primarily used for drawn thread hemstitching. It can also be used for sewing over thin tape in a contrasting or same color. Place the stitch in the center and a special effect will be obtained for decoration. Another use for the ladder stitch is couching over narrow ribbon, yarn or elastic. For drawn thread work, choose a coarse linen type fabric and after sewing draw the thread out within the ladder for an open airy appearance.

				
		5.0	2.5	3-5

Set up for ladder stitch

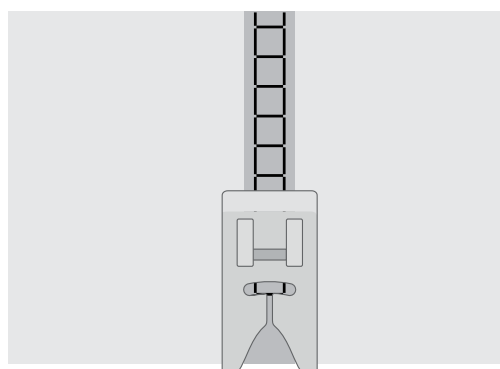

More Decorative Stitches & Ideas For Decorative Machine Stitching

You should carry out a test sewing on an extra piece of the fabric being sewn to check the decorative pattern to be used. Before starting to sew, check that there is enough thread wound onto the bobbin to ensure that the thread will not run out during sewing. For best results, stabilize fabric with a tear-away or wash-away stabilizer underneath when stitching.

Darning and Mending





Repair Large Holes

To cover large holes it is necessary to sew a new piece of fabric onto the damaged area.





Baste the new piece of fabric onto the damaged area on the right side of the fabric.

Sew over the fabric edges with the zigzag or the multi-step zigzag stitch.

Trim the damaged area close to the seam from the wrong side of the fabric.

				
		4.0–6.0	2.0	3–5

Set up for zigzag

				
		3.0–5.0	1.0	3–5

Set up for multi-step zigzag stitch

Repair Tears

On tears, frayed edges or small holes it is useful to lay a piece of fabric on the wrong side of the fabric. The underlaid fabric reinforces the damaged area.

Lay a piece of fabric underneath the damaged fabric. It must be a little larger than the damaged area.

Sew over the damaged area using the zigzag or multi-step zigzag stitch.

Trim the piece of fabric used as reinforcement.

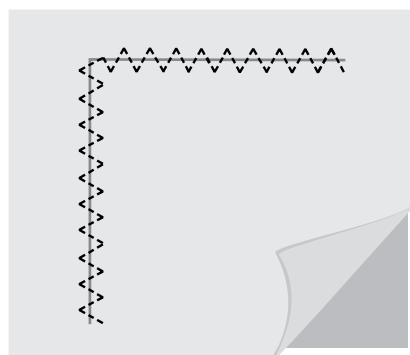
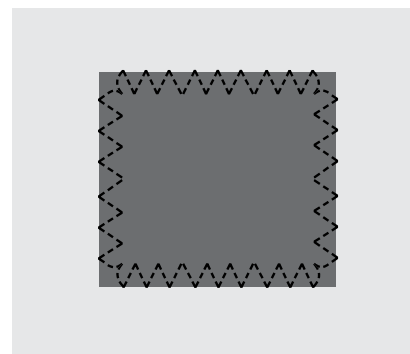





One-Step Buttonhole

Sew buttonholes perfectly sized for your button. The fabric should be interfaced and/or stabilized where buttonholes are to be sewn.

1. Mark the start position of the buttonhole on the fabric (A).
2. On the One-Step Buttonhole Foot, push the button holder open by pushing the lever backwards (B). Insert the button. Push the button holder forward until the button is locked in place (C). The button will determine the length of the buttonhole. The distance between the button holder lever (B) and the stopper (D) is the length of the buttonhole.
3. Attach the One-Step Buttonhole Foot.
4. Make sure that the thread is pulled through the hole in the presser foot and placed under the foot.
5. Position your fabric under the presser foot so that the marking on the fabric is aligned with the center of the Buttonhole Foot (E).
6. Lower the Buttonhole Lever (F) all the way down. The buttonhole lever should fit between the button holder lever (B) and the stopper (D).
7. Hold the end of the upper thread and start sewing. The buttonhole is sewn from the front of the presser foot to the back. Stop sewing when the buttonhole is finished.
8. Once the buttonhole is sewn, raise the presser foot. Push the buttonhole lever all the way up.
9. To secure the bartack, thread the end of the top thread into a hand sewing needle, pull to the wrong side and tie the end before cutting excess thread.
10. Use a seam ripper and cut the buttonhole open from both ends towards the middle (G).

If you want to sew another buttonhole, do not push the buttonhole lever up when the buttonhole is finished. Sew another buttonhole.

Note: Always sew a test buttonhole on a piece of scrap fabric.

				
		5.0	0.4	3-5

Set up for buttonhole

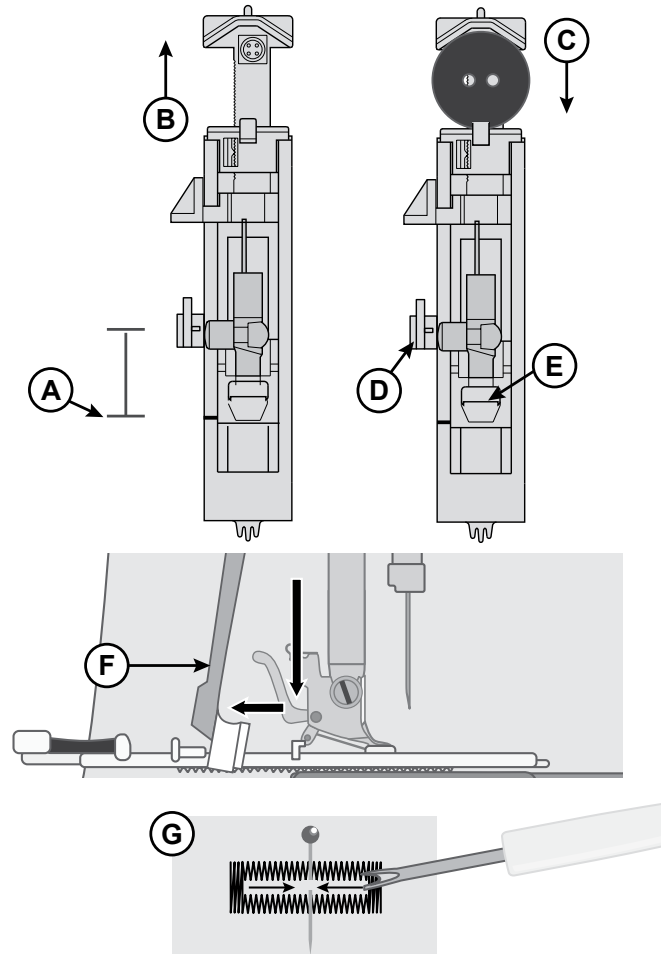





Sew Zippers

The Zipper Foot can be attached on either the right or the left of the needle, making it easy to sew both sides of the zipper.

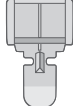
To sew the right side of the zipper, attach the foot in the left presser foot position (A).

To sew the left side of zipper, attach the foot in the right presser foot position (B).

				
		3.5	2.0-3.0	3-5

Set up for sewing zippers

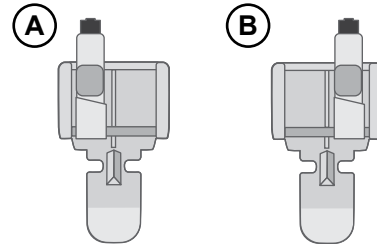

Centered Zipper



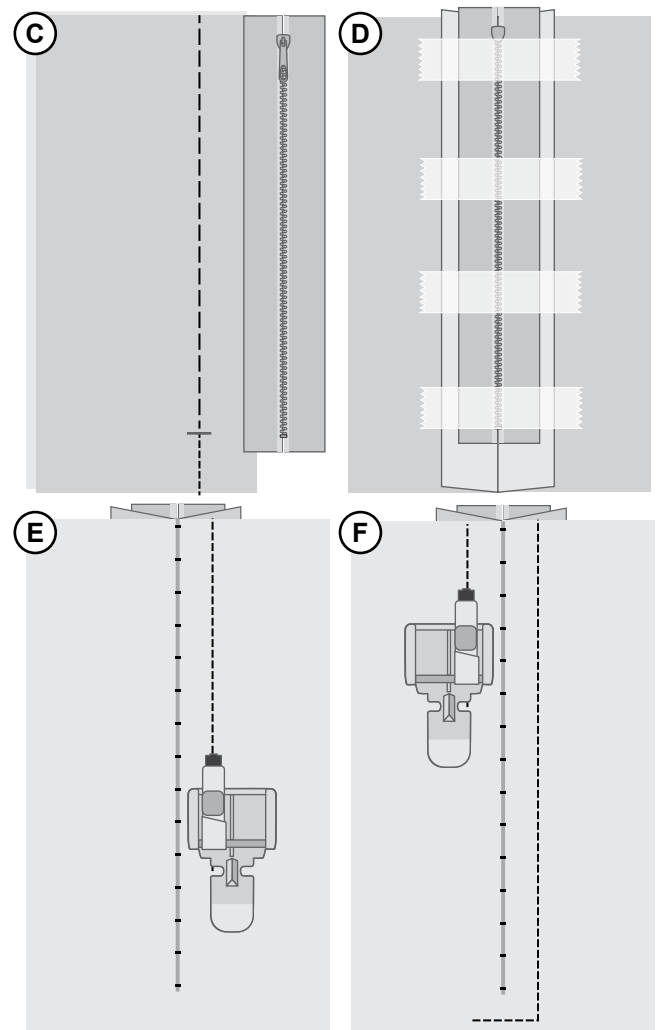

- Place the fabric pieces right sides together and pin. Mark the zipper length on your fabric.
- Baste the zipper seam using the specified seam allowance (use straight stitch with stitch length 4mm, thread tension 2). Baste to the end of zipper marking (C).
- Set up the machine for straight stitch (see table above), backstitch a few stitches and sew the rest of the seam using the specified seam allowance (C).
- Press the seam allowances open. Place the right side of the zipper to the wrong side of the seam, tape in place (D).
- Flip your project, making sure that the right side is facing up. Snap on the Zipper Foot, to the left side of the needle (A).
- Sew along the right side of the zipper to the end of your zipper, remember to backstitch in the beginning. Stop with the needle down in the fabric, lift the presser foot and turn your project to sew across the bottom of the zipper (E).
- Attach the Zipper Foot to the right side of the needle (B). Sew the remaining zipper side as you did with the first side (F).
- Flip your project to remove the tape on the back side.
- Flip your project to the right side again and remove the basting stitches.

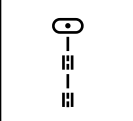

Hand-Look Quilt Stitch

Simulate the look of hand sewn quilting with the Hand-look Quilting stitch. Thread the needle with either transparent thread or with a thread that blends with the color of the top of the fabric. Thread the bobbin with a thread color that coordinates or contrasts with the top of the fabric, depending on the look you want for your project (the bobbin thread will actually appear on the top of the fabric).

- To get the accurate hand stitched look it is important that the stitch is sewn using a high thread tension. Make sure to set the tension according to the recommendations in the stitch chart.
- Stitch along one of the seams of your project, or around an appliqué. The handlook effect is created as the bobbin thread is pulled up to the top of the fabric.
- Use the quilting guide to make even rows of channel quilting or echo quilting as illustrated. Insert the Edge/Quilting Guide into the groove at the back of the presser foot holder and adjust the position to fit your project.

				
		3.5	2.0-3.0	6-9

Set up for hand-look quilt stitch

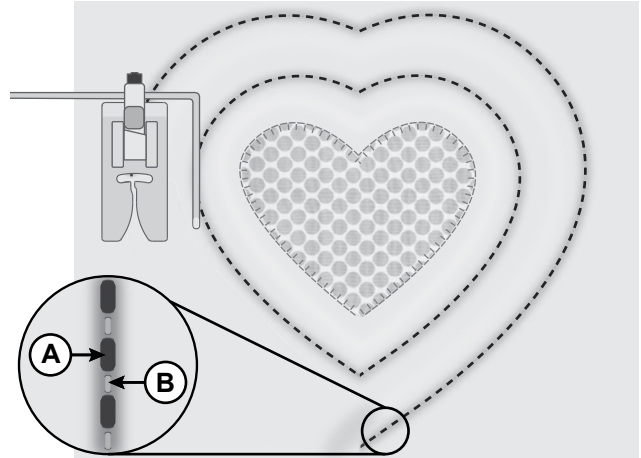





A. Bobbin thread
B. Needle thread

Button Sewing

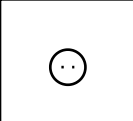
Fasten buttons easily and quickly with the special button sewing stitch.

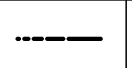
1. Select the Button Sewing Stitch.
2. Attach the Darning Plate to cover the feed teeth.
3. Attach the Button Sewing Foot to your machine.
4. Mark the placement of the button with a marking pen (A).
5. Place your project under the presser foot, place the button under the foot aligning it with the marking on the fabric. Lower the presser foot (B).
6. Turn the handwheel toward you very slowly to be sure the needle clears the holes. Adjust the stitch width if needed (C).
7. Start sewing at a low speed. The machine stops automatically after a few stitches.
8. Leave a long thread tail and pull it under the button. Wind the thread tail around the shank.
9. Use a hand sewing needle to pull the thread to the wrong side of the fabric and secure.
10. When finished sewing all buttons, remove the Darning Plate.

				
		3.5	—	2-4

Set up for button sewing

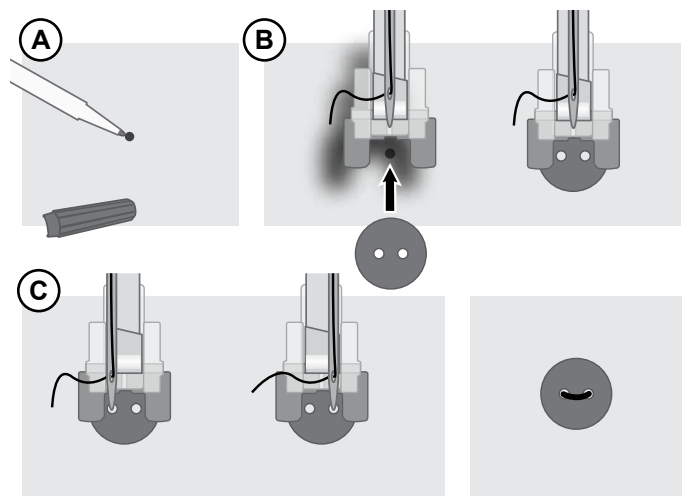

MAINTENANCE

Cleaning the Machine

To ensure the best possible operation of your machine, it is necessary to keep the essential parts clean at all times. Always disconnect the machine from power supply by removing the plug from the socket-outlet.

Cleaning the Feed Teeth and Shuttle Area

 *Raise the needle and turn off the machine.*

Tip: Cleaning the shuttle area might be easier if you lay the machine down on a flat surface.

1. Raise the needle to its highest position.
2. Remove the bobbin case from the shuttle.
3. Push aside the two shuttle keepers.
4. Remove the shuttle race cover and shuttle.
5. Clean the feed teeth and shuttle area with the lint brush.
6. Lower the needle slightly so that the shuttle race forms a half moon on the left side of the shuttle area.
7. Hold the shuttle by its center pin, as a half moon on the right side of the shuttle area. Position the “fork” at the lower part of the shuttle around the lower left part of the shuttle race and push it into the shuttle area.
8. Slide the shuttle race cover back into position.
9. Snap the shuttle keepers back into position.

NOTE: Put a drop of sewing machine oil on the center pin of the shuttle and shuttle race as indicated by the arrows.

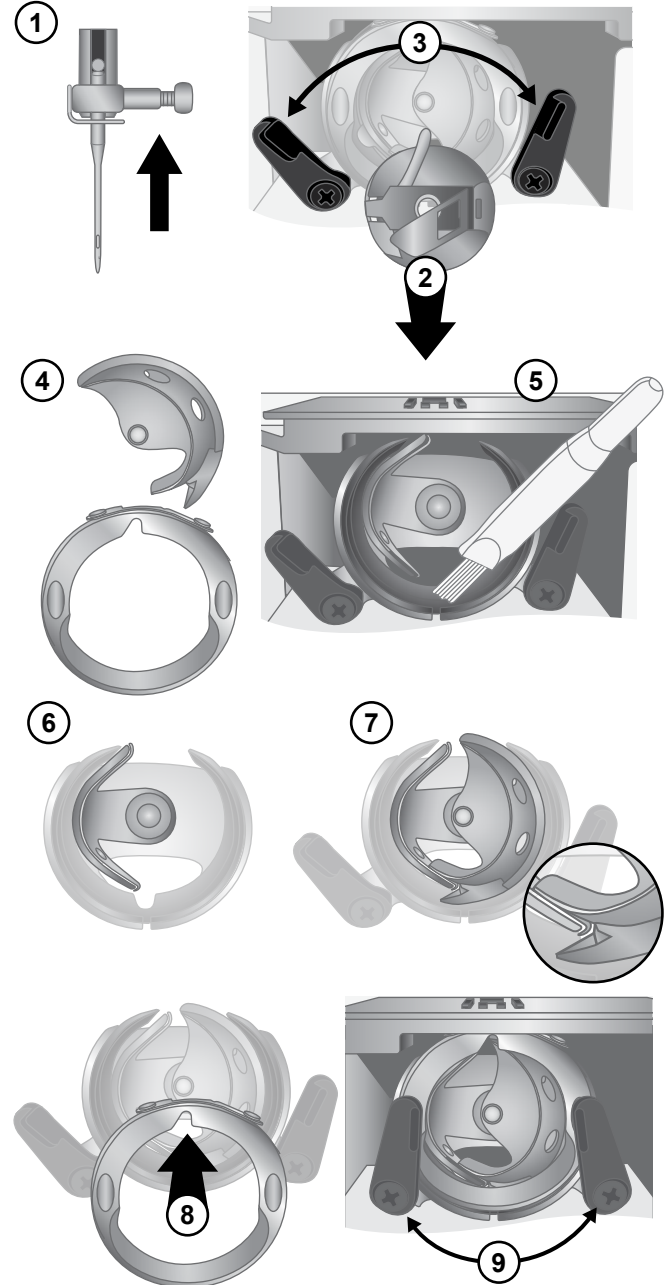

Cleaning The Sewing Machine And Foot Control

 *Raise the needle and turn off the machine.*

After using, keep sewing machine and foot control clean, use dry rags to remove dust from the sewing machine and foot control.

NOTE: Use dry rags to avoid electrical shock.

Troubleshooting

Thread Loops on Underside of Fabric

Possible cause: Thread looping on the underside of the fabric is always an indication that the upper thread is not correctly threaded. This happens when the upper thread is not correctly placed in the thread tension mechanism and has not been threaded through the take up lever.

Solution: *Rethread the machine, making sure to first raise the presser foot lifter before starting to thread, so thread can be properly seated in the tension mechanism and take up lever. To know if you have rethreaded the machine correctly, try this test:*

- Raise the presser foot lifter and thread the top of the machine.
- Thread the needle, but don't put the thread under the presser foot yet. As you pull the upper thread to the left, it should pull freely.
- Put the presser foot lifter down. As you pull the upper thread to the left, you should feel resistance. This means you are threaded correctly.
- Put the thread under the presser foot, and then draw up the bobbin thread. Slip both thread tails under the presser foot towards the back. Lower the presser foot and begin sewing.

If you put the presser foot lifter down, but the thread still pulls freely (you feel no difference whether the presser foot is up or down), this means that you have threaded incorrectly. Remove the upper thread and rethread the machine.

Bobbin Thread Breaking

Possible cause: Bobbin threaded incorrectly.

Solution: *Check that bobbin is placed correctly in the bobbin holder.*

Possible cause: Bobbin wound too full or unevenly.

Solution: *Bobbin thread may not have been correctly placed into bobbin winding tension disc during the bobbin winding process.*

Possible cause: Dirt or lint in bobbin holder.

Solution: *Clean bobbin holder.*

Possible cause: Wrong bobbins being used.

Solution: *Use bobbins that are the same style as those that come with the machine (SINGER® Class 15 metal bobbins) – don't substitute.*

Bobbin Thread Showing on Top of Fabric

Possible cause: Top thread too tight.

Solution: *Reduce upper thread tension.*

Possible cause: Thread path is obstructed, putting extra tension on top thread.

Solution: *Check that the top thread path is not obstructed and thread is moving freely through the thread path.*

Possible cause: Bobbin thread not in bobbin case tension.

Solution: *Rethread bobbin.*

Bobbin Winding Difficulties

Possible cause: Bobbin thread loosely wound on bobbin.

Solution: *Rewind bobbin, making sure that the thread is placed snugly in the bobbin winding tension disc.*

Possible cause: Bobbin winding spindle not fully engaged, therefore bobbin not winding.

Solution: *Check that the bobbin winding spindle has been fully engaged before starting to wind.*

Possible cause: Bobbin is winding sloppily because thread end not held at beginning of winding process.
Solution: *Before starting to wind, hold the thread tail (coming out of the bobbin) securely, allow the bobbin to partially fill, then stop to trim the thread tail close to the bobbin.*

Fabric Puckers

Possible cause: Top thread is too tight.
Solution: *Reduce top thread tension.*

Possible cause: Stitch length is set too short.
Solution: *Increase stitch length setting.*

Possible cause: Wrong style needle for fabric type.
Solution: *Use correct needle style and size for your fabric.*

Fabric Is Tunneling Under Stitches

Possible cause: Fabric is not properly stabilized for the density of the stitches (for example, satin stitch applique).
Solution: *Add a fabric stabilizer underneath the fabric to help keep the stitches from tunneling in together, forming a puckered ridge in fabric.*

Loud Noise When Sewing

Possible cause: Thread not in take-up lever.
Solution: *Rethread the machine, making sure the take up lever is in its highest position so thread goes in the eye of the take up lever — turn machine hand wheel toward you to raise the take up lever to its highest position for threading.*

Possible cause: Thread path is obstructed.
Solution: *Check that thread is not caught on the thread spool or behind the spool cap.*

Machine is Not Feeding Fabric

Possible cause: Presser foot lifter has not been lowered onto fabric after threading.
Solution: *Lower the presser foot lifter before starting to sew. Don't "push" or "pull" the fabric as you sew.*

Possible cause: Stitch length is set at zero.
Solution: *Increase stitch length setting.*

Machine Will Not Run

Possible cause: Bobbin winding spindle is engaged when you try to sew.
Solution: *Disengage bobbin winding spindle by pushing it to the left.*

Possible cause: Power cord and/or foot control not plugged in correctly.
Solution: *Make sure power cord/foot control are correctly seated in machine and power supply.*

Possible cause: Wrong bobbins being used.
Solution: *Use bobbins that are the same style as those that come with the machine (SINGER® Class 15 metal bobbins)— don't substitute.*

Needles Breaking

Possible cause: Bent, dull or damaged needle.
Solution: *Discard needle, insert new needle.*

- Possible cause:** Wrong size needle for fabric.
Solution: *Insert appropriate needle for fabric type.*
- Possible cause:** Machine not threaded correctly.
Solution: *Rethread the machine completely.*
- Possible cause:** “Pushing” or “pulling” fabric.
Solution: *Don't manually push/pull fabric in order to sew, but allow the machine's feed teeth to draw fabric under the presser foot as you guide it.*

Needle Threader Not Working

- Possible cause:** Needle not in correct position.
Solution: *Raise needle to its highest position by turning hand wheel toward you.*
- Possible cause:** Needle is not correctly inserted.
Solution: *Needle all the way up in the needle clamp.*
- Possible cause:** Needle is bent.
Solution: *Remove the bent needle, insert new needle.*
- Possible cause:** Hook pin damaged.
Solution: *Needle Threader needs replacement. Contact authorized service center.*

Skipping Stitches

- Possible cause:** Needle inserted incorrectly.
Solution: *Check that flat side of needle top is toward back of machine and needle is up as far as it can go, then tighten needle clamp screw.*
- Possible cause:** Wrong needle for fabric sewn.
Solution: *Use correct needle style and size for your fabric.*
- Possible cause:** Bent, dull or damaged needle.
Solution: *Discard needle and insert new needle.*

Stitches Distorted

- Possible cause:** “Pushing” or “pulling” the fabric.
Solution: *Don't manually push/pull fabric in order to sew, but allow the machine's feed teeth to draw fabric under presser foot as you guide it.*
- Possible cause:** Incorrect stitch length setting.
Solution: *Adjust stitch length setting.*
- Possible cause:** Stabilizer may be needed for technique.
Solution: *Place stabilizer underneath fabric.*

Thread Bunching at Beginning

- Possible cause:** Top and bobbin threads have not been properly placed underneath presser foot before starting to sew.
Solution: *Ensure that both the top thread and the bobbin thread are under the presser foot and toward the back before starting to sew.*
- Possible cause:** Sewing was started with no fabric under the presser foot.
Solution: *Place fabric under foot, making sure that needle comes down into fabric; lightly hold both thread tails for first few stitches.*

Possible cause: Stabilizer may be needed for technique.

Solution: *Place stabilizer underneath fabric.*

Upper Thread Breaking

Possible cause: Thread path obstructed

Solution: *Check if thread is caught on thread spool (rough spots on the spool itself) or behind spool pin or spool cap (if the thread has fallen behind the spool cap and therefore cannot feed freely through the machine path).*

Possible cause: Machine is not threaded correctly.

Solution: *Remove upper thread completely, raise presser foot lifter, rethread machine making sure thread is in take-up lever (raise take up lever to its highest position by turning hand wheel toward you).*

Possible cause: Upper tension too tight.

Solution: *Reduce upper thread tension.*

Technical Specification

Sewing Speed Maximum 700 ± 50 rpm (using straight stitch with default stitch length)	Rated Voltage 240 V/50Hz, 230 V/50Hz, 220 V/50-60Hz, 127 V/60 Hz, 120 V/60 Hz, 125 V/60 Hz, 100V/50-60Hz	Presser Foot Rise Height 6mm
Protection Class II (Europe)	Stitch Width 0–6.5mm	Stitch Length 0–4.5mm
Type of Lamp LED light	Machine Dimensions Length: ≈431mm Width: ≈223mm Height: ≈312mm	Weight 5.6kg

We reserve the right to change the machine equipment and the assortment of accessories without prior notice, or make modifications to the performance or design. Such modifications, however, will always be to the benefit of the user and the product.

INTELLECTUAL PROPERTY

SINGER, and the Cameo “S” Design, are exclusive trademarks of The Singer Company Limited S.à.r.l. or its Affiliates.

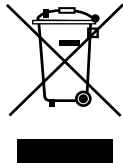

Please note that on disposal, this product must be safely recycled in accordance with relevant National legislation relating to electrical/electronic products. Do not dispose of electrical appliances as unsorted municipal waste, use separate collection facilities. Contact your local government for information regarding the collection systems available. When replacing old appliances with new ones, the retailer may be legally obligated to take back your old appliance for disposal free of charge.

If electrical appliances are disposed of in landfills or dumps, hazardous substances can leak into the groundwater and get into the food chain, damaging your health and well-being.

IMPORTER TO THE UK:
VSM UK
Ravensbank House, Ravensbank Drive
North Moons Moat, Redditch. B98 9NA, United Kingdom

MANUFACTURER
VSM Group AB, SVP Worldwide
Soldattorpsgatan 3, SE-55474 Jönköping, SWEDEN



SINGER[®]

ORIGINAL SINCE 1851.